

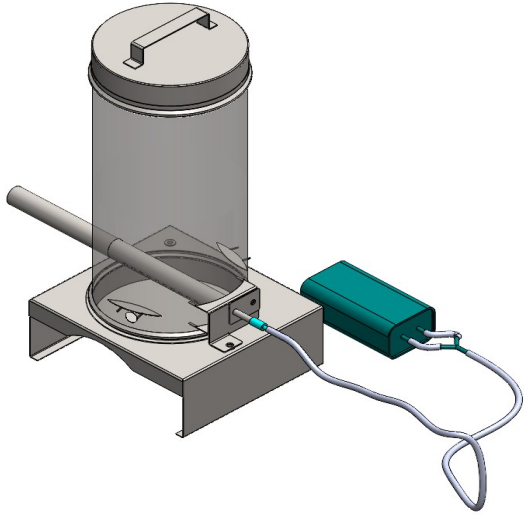

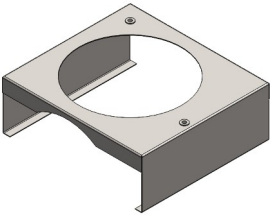



# TISKRE-DO

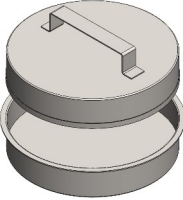
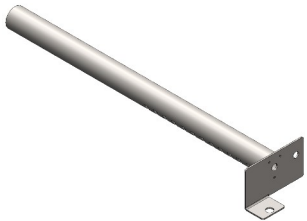
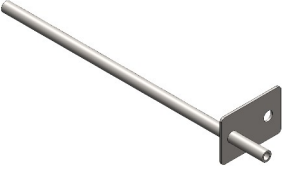

## **TISKRE – DO** *Cold Smoke Generator with Passive Cooler* **SG1**

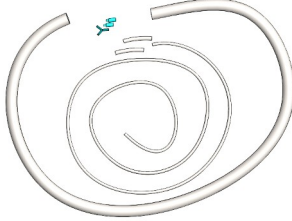
SG1 is a universal smoke generator for cold and hot smoking of meat, fish, cheese, seafood, and vegetables. Two universal adapters allow easy connection to any ceramic or metal grill.

 <p>stand</p>	 <p>Wood container 140mm</p>	 <p>Caps 140mm</p>	 <p>Burner</p>
 <p>Air injector</p>	 <p>Compressor YE-922</p>	 <p>Thermo silicone hoses</p>	 <p>Alder smoking chips 1L</p>

## Operating Instructions

1. Ensure a firm and secure attachment at both 140mm caps.
2. Use the Appropriate Wood Chips Size: Select wood chips 2-8mm size.
3. Avoid forcefully packing wood into the container: Do not press down or stomp on the wood chips.
4. Ignite the wood chips properly: Ensure they are burning steadily for efficient operation.
5. Clean all parts after each use: This ensures optimal performance and longevity of the device.

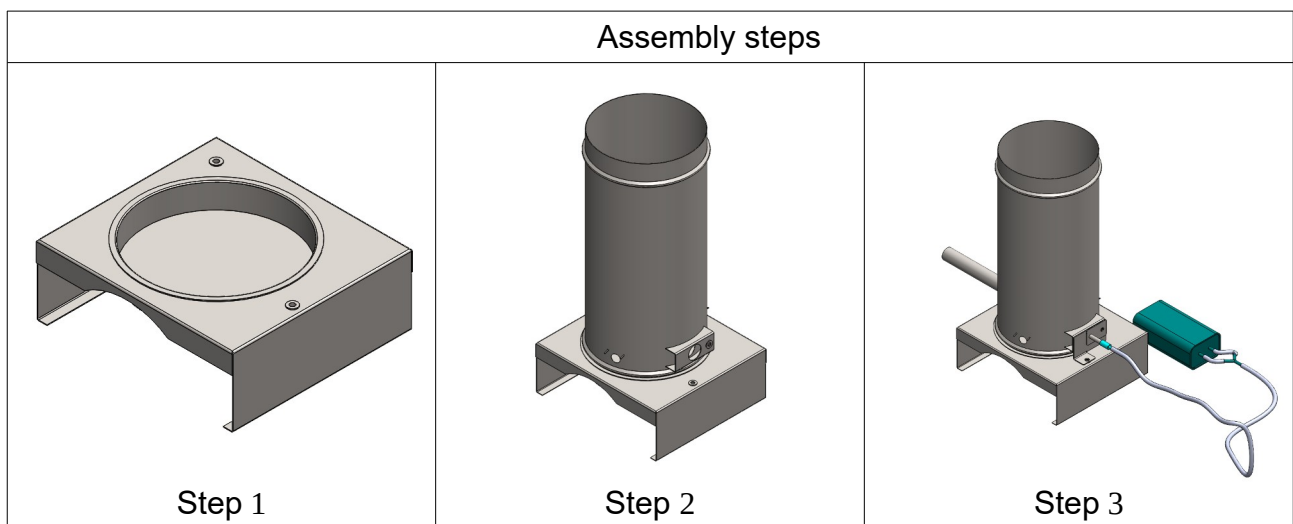

## Safety Precautions

1. Do not place the smoke generator on flammable surfaces:  
Always use the generator on a stable, heat-resistant surface to prevent the risk of fire.
2. Wear protective gloves when cleaning:  
Use rubber gloves to protect your hands from sticky tar residue and strong cleaning agents.

